

# Eclipse ThermJet

## Burners

Model TJ0100  
Version 2

PARAMETER	BURNER VELOCITY		MODEL TJ0100
Maximum input Btu/hr (kW)	Medium & High Velocity		1,000,000 (293)
Minimum Input, on-ratio Btu/hr (kW)	Medium & High Velocity		100,000 (29)
Minimum Input, fixed air Btu/hr (kW)	Medium & High Velocity		20,000 (6)
Gas inlet pressure required "w.c. (mbar) • Fuel pressure at gas inlet (Tap "B" – see page 3)	High Velocity	Nat. Gas Propane Butane	12.5 (31.0) 13.5 (34.0) 14.5 (36.0)
	Medium Velocity	Nat. Gas Propane Butane	5.5 (14.0) 8.0 (20.0) 7.5 (19.0)
Air inlet pressure required "w.c. (mbar) • 15% excess air at maximum input (Tap "A" – see page 3)	High Velocity	Nat. Gas Propane Butane	16.5 (41.0) 17.0 (43.0) 17.0 (43.0)
	Medium Velocity	Nat. Gas Propane Butane	9.0 (23.0) 9.0 (23.0) 9.0 (23.0)
High Fire Flame Length Inches (mm) (measured from end of combustor)	High Velocity	Nat. Gas Propane Butane	33 (835) 34 (865) 35 (890)
	Medium Velocity	Nat. Gas Propane Butane	38 (965) 37 (940) 42 (1065)
Maximum flame velocity ft/s (m/s) • 15% excess air, at maximum input	High Velocity		500 (152.4)
	Medium Velocity		250 (76.2)
Maximum combustion air temperature	300° F (149 °C) For higher temperatures, use TJPCA (Data 206)		
Flame detection	U.V. scanner available for all combustors. Flame Rod available for use with alloy or silicon carbide combustors only.		
Fuel	Natural Gas, Propane, Butane <i>For any other mixed gas, contact Eclipse for orifice sizing.</i>		

- All information is based on laboratory testing in neutral (0.0" w.c.) pressure chamber. Different chamber size and conditions may affect the data.
- All information is based on standard combustor design. Changes in the combustor will alter performance and pressures.
- All inputs based upon gross calorific values.
- Eclipse reserves the right to change the construction and/or configuration of our products at any time without being obliged to adjust earlier supplies accordingly.
- Plumbing of air and gas will affect accuracy of orifice readings. All information is based on generally acceptable air and gas piping practices.
- Do not install the burner with the gas inlet rotated 90° clockwise with respect to the air inlet if operating on natural gas using a flame rod.

## Performance Graphs

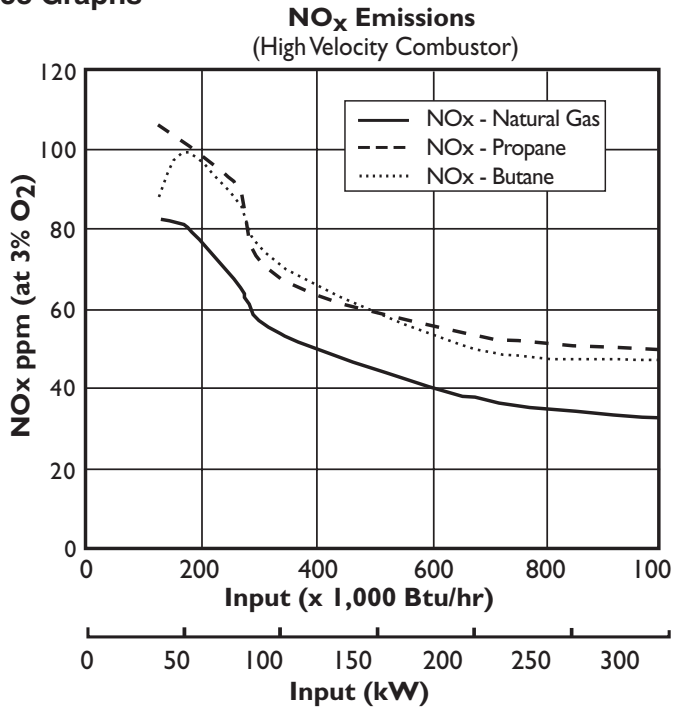
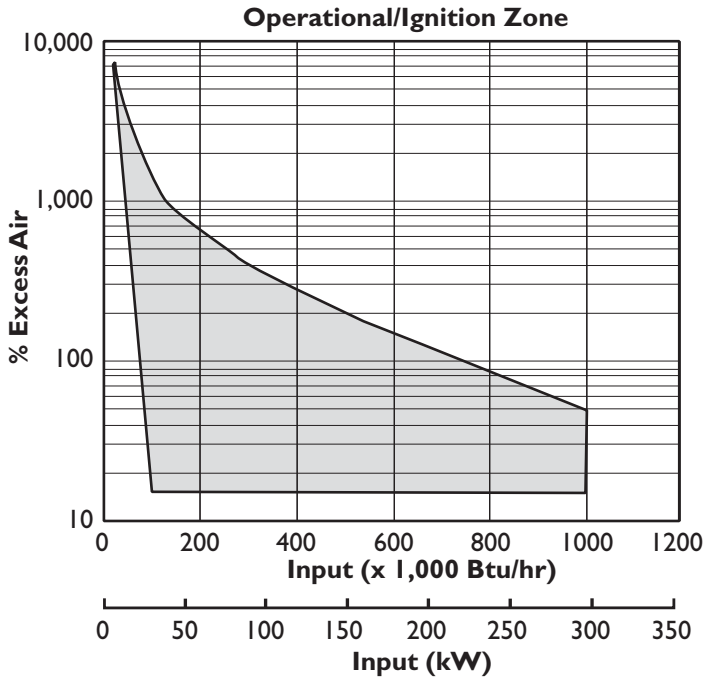

Correction factor for medium velocity combustor is 1.20  
 On ratio: combustion air is adjusted to 3% O<sub>2</sub> at any given input.

Emissions from the burner are influenced by:

- fuel type
- combustion air temperature
- firing rate
- chamber conditions
- percent of excess air

For estimates of other emissions, contact Eclipse.

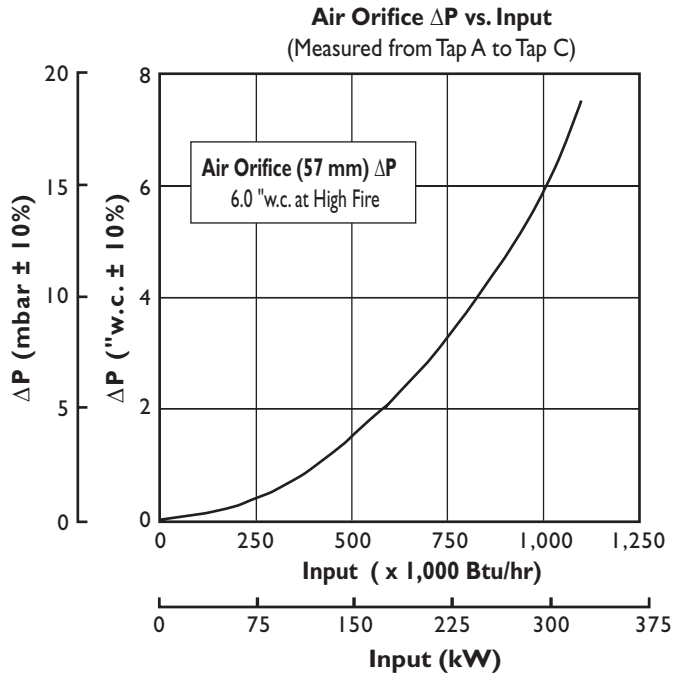
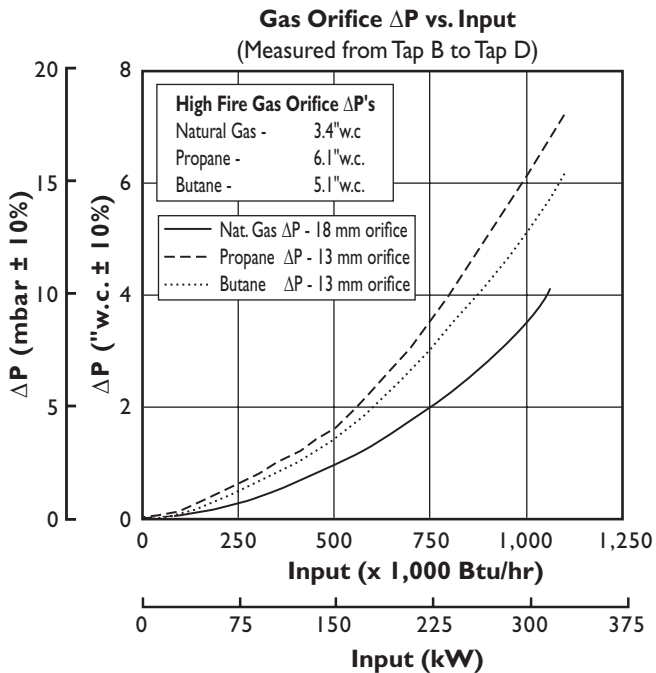

## Dimensions & Specifications Millimeters (Inches)

### Burner Housing

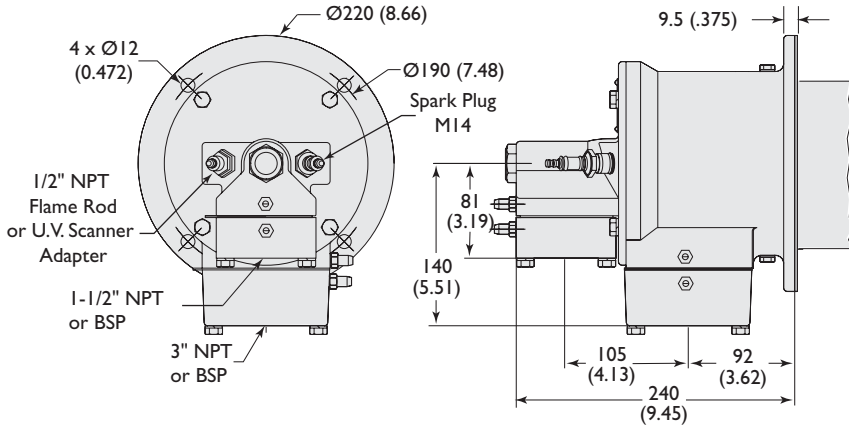

Burner weight less combustor: 42 lb (19 kg)

### Tap Locations

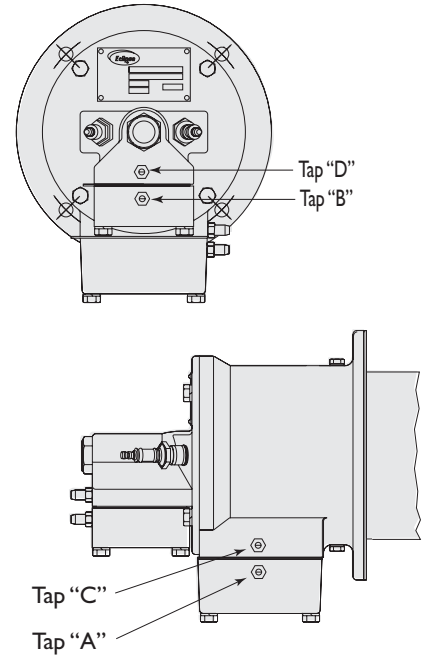

### Combustor

Exhaust outlet diameter : High Velocity :  $\text{Ø}54$  (2.125)  
Medium Velocity :  $\text{Ø}76.4$  (3.0)

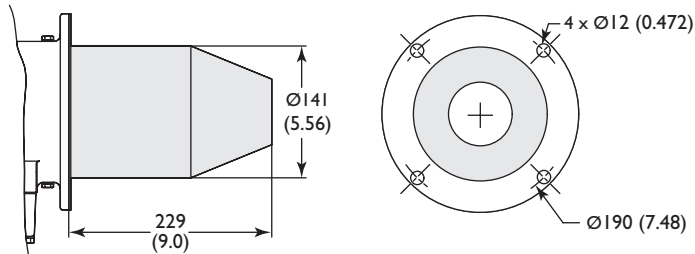

#### **Alloy Tube (AISI 310)**

Weight: 3.2 lb (1.45 kg)  
Max Chamber Temp: 1,750°F (950°C)

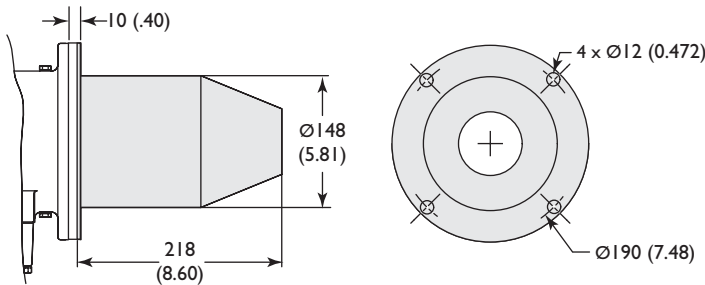

#### **Silicon Carbide Tube**

Weight: 3.2 lb (1.45 kg)  
Max Chamber Temp: 2,500°F (1371°C)

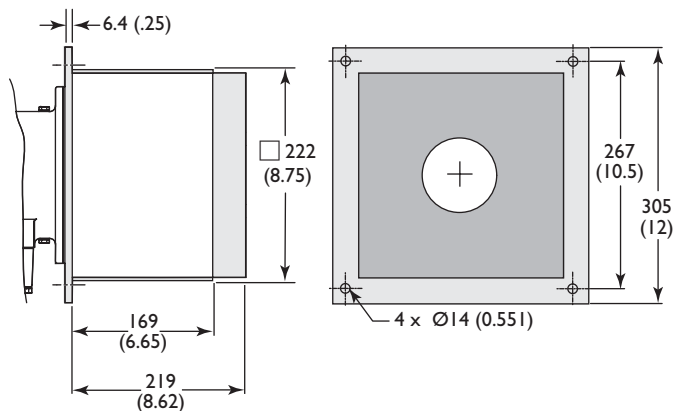

#### **Refractory Block (w/RA330 wrapper)**

Weight: 61.3 lb (28 kg)  
Max Chamber Temp: 2,800°F (1538°C)

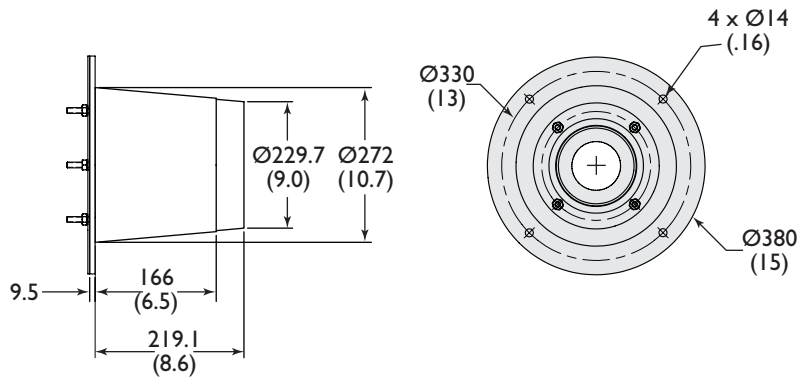

**Down Firing Block**

Weight: 75 lb (34 kg)

Max. Chamber Temp: 2800°F (1535°C)



**Offered By:**

Power Equipment Company  
2011 Williamsburg Road  
Richmond, Virginia 23231  
Phone (804) 236-3800  
Fax (804) 236-3882

---

[www.peconet.com](http://www.peconet.com)